

# UKM

# ULTRASONIC HEAT METER

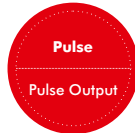
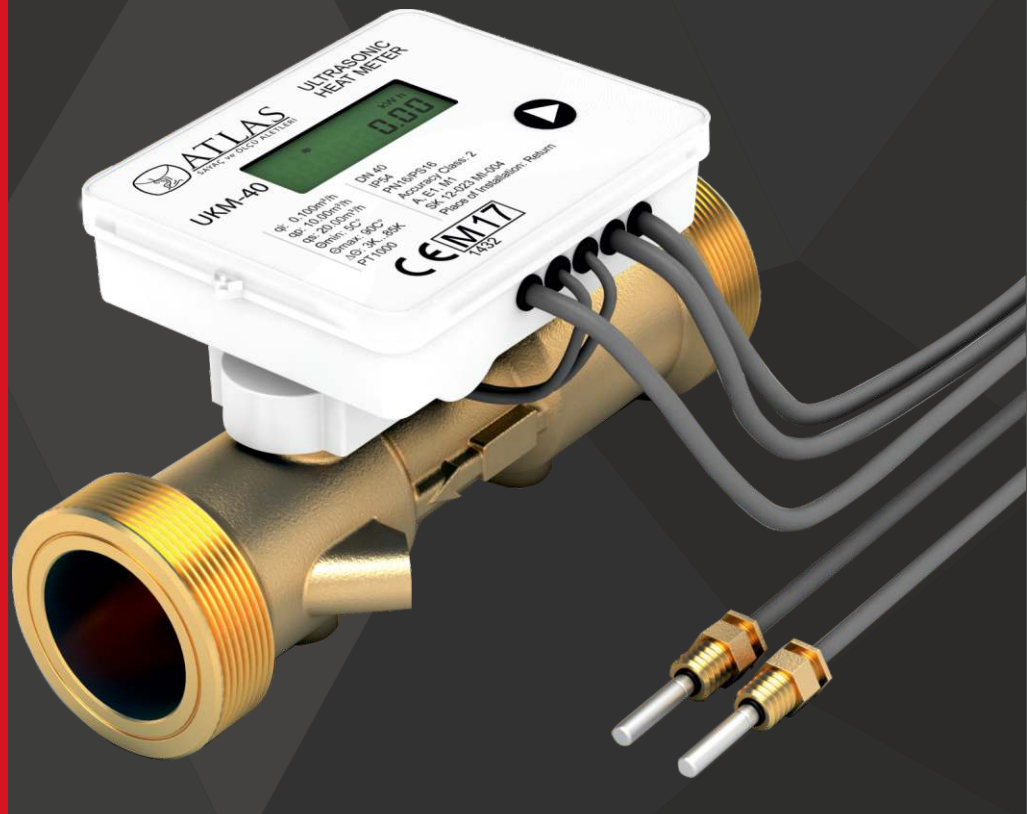

## PACKAGE INCLUSINGS

### Standard

- UKM 40 Ultrasonic Heat Meter (1 pcs)
- User Manual and Installation Guide.

### Optional

- Sensor connection sleeve
- Sensor ball valve
- Hybrid Heat Meter

(Technical Drawing)

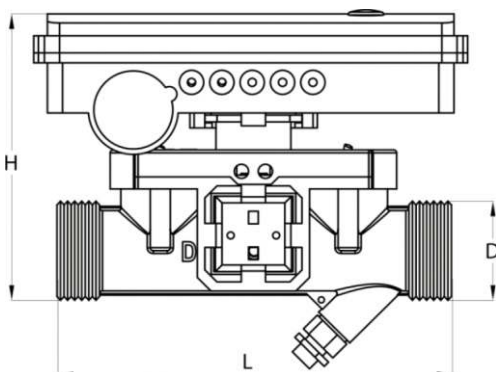

<b>DN(D)</b>	<b>40</b>
Length (L) Height (H) /Width (W)	200 mm/ 120 mm / 83 mm
Sensor , M- Bus Cable	1,5 m
Weight	1250 gr

## PRODUCT FEATURES

- UKM is Produced according to MID ( Measurement Instrument Directive) and EN1434
- There is no moving mechanism or component used in UKM so the life term is longer than the mechanical meters. The Ultrasonic measuring method is more accurate than the mechanical measuring methods by the way UKM accuracy grade is better than the regular mechanical meters. The battery life is up to 10 years with the low energy consumption.
- It is easy to use with its demountable LCD screen.
- It has statistical storage to get data query of the last 12 months consumptions.
- M-Bus and RF interfaces are available.
- UKM has the Thermal sensor pair that is capable of linear measurement.

## TECHNICAL FEATURE

### Ultrasonic Flow Meter:

- Accurate measurement at low flow rates
- Flow metering range:
  - Minimum Flow (qi) : 0,10m<sup>3</sup>/h
  - Nominal Flow(qp) : 10,00m<sup>3</sup>/h
  - Maximum Flow (qs) : 20,00m<sup>3</sup>/h

### Thermal sensor pair that is capable of linear measurement

- The minimum temperature difference( $\Delta t$ ) that the calculation starts is 0,1°C
- Fast reacting Platinum Thermal sensor pair is used.
- The Measurement temperature range is between 5o C and 90 °C

### Metrological Options

- Produced according to the standards of TS EN 1434
- The accuracy class is 2 ( Class 2)
- Protection Class is IP65
- Maximum pressure can be applied to (MAP) is 16 bar.

### Communication Interfaces:

- The Wired communication has Standard M-Bus interface
- RF communication uses wireless M-Bus interface.
- Produced according to the 2014/32/EU MID ( Measurement Instrument Directives)